



VIVA L

INSTALLATION MANUAL (ENGLISH)

RAIS[®]

attika[®]
FEUERKULTUR

PRODUCTION NUMBER

The production number is located on the back of the stove and on the first page of the user manual.



THIS MANUAL APPLIES TO THE FOLLOWING MODELS:

- Viva L 100
- Viva L 120
- Viva L 140
- Viva L 160
- Viva L Baking Compartment (BC)



CONTENT

| | |
|---|----|
| PRODUCTION NUMBER | 2 |
| INSTALLATION MANUAL | 4 |
| Malfunctions | 5 |
| TECHNICAL DATA | 6 |
| Specifications | 6 |
| INSTALLATION DISTANCE | 8 |
| Furnishing distance for stoves with a rotating base | 8 |
| Installation distances at combustible walls | 9 |
| Installation distances for non-combustible walls | 10 |
| DIMENSIONAL SKETCHES | 12 |
| INSTALLATION | 21 |
| Recycling of packaging | 21 |
| Packaging at delivery | 22 |
| Height adjustment | 22 |
| Installation of smoke outlet in top outlet | 23 |
| Changing the chimney connection | 23 |
| Removing the combustion chamber lining | 24 |
| Heat accumulation stones | 24 |
| Mounting the top plate | 25 |
| Mounting/changing the handles | 25 |
| Swivel base | 26 |
| CLEANING AND MAINTENANCE | 27 |
| EXTERNAL AIR CONNECTION - AIRSYSTEM | 28 |
| Air connection on the back | 28 |
| Air connection at the bottom | 29 |
| SPECIAL PRECAUTIONS FOR INSTALLATION IN UK | 30 |

INSTALLATION GUIDE

Thank you for choosing your new RAIS or ATTIKA product! This installation instructions manual will ensure that your stove is installed correctly and that it will provide you with comfort and pleasure for many years to come.

GENERAL

It is important to correctly install the stove out of consideration for both the environment and personal safety. The installation must comply with all local rules and regulations, including those that refer to national and European standards. A certified chimney sweeper should be contacted before set-up. No unauthorised alterations may be made to the stove.

Upon receipt, inspect the stove for any transport damage. Do not install the stove until you have checked it thoroughly.

FLOOR CONSTRUCTION

The floor structure must be able to support the weight of the stove and a chimney, if required. If the existing floor structure does not meet this requirement, suitable measures must be taken (e.g. installation of a load distribution plate). If in doubt, contact a building expert.

National and local regulations must be complied with, including the size of the non-flammable plate that must cover the flammable floor in front of the stove to protect the floor from falling embers.

DISTANCE TO COMBUSTIBLE MATERIAL

The stove must be positioned at a safe distance from flammable material. Due to risk of fire, flammable items (e.g. furniture) may not be positioned closer to the insert than specified in the sections on placement. When deciding where to install your RAIS/ATTIKA stove, you should consider being able to heat other rooms in your home to get the most out of your new stove.

VENTILATING SYSTEMS

The stove needs permanent and sufficient air to operate safely and efficiently. A permanent air supply can be

installed in the room for the stove's combustion air - through the AirSystem connection. Under no circumstances should this air supply be closed during operation. Note that any mechanical extraction such as a cooker hood can reduce the air supply. The stove has an air consumption of min. 12.9 m³/h.

CHIMNEY

As a minimum, the chimney must be constructed of T400-N1-D-50050-G100 flue pipe, and be tall enough that the draught conditions are in order, i.e. 12 pascal to 18 pascal. If the recommended chimney draught cannot be achieved, problems of smoke puffing from the door may arise when heating. The collar is 147 mm in diameter. Remember: there must be unobstructed access to the access door on the chimney.

If the draught is too strong, it is advisable to equip the chimney with a regulating damper. If a regulating damper is fitted, you must ensure that there is a free flow-through area of at least 20 cm² when the regulating damper is closed.

The length of the chimney, calculated from the top of the stove should not be less than 3 metres and must be at least 80 cm above the roof ridge. If the chimney is placed on the side of the house, the top of the chimney must never be lower than the roof ridge or the roof's highest point. Note that there are often national and local regulations relating to houses with thatched roofs.

Always make sure to comply with applicable standards (EN 15287-1:2023 and EN 15287-2:2023) for chimney installation. It is also important to check the correct functioning of the chimney according to EN 13384-2:2015+A1:2019 based on the individual solution on site.

ROOM SIZE

Room size requirements apply to the product with the type designation CA. Type CA refers to room sealed stoves with a self-closing door that has been tested for tightness. The room in which the stove is installed must be at least 40 m³. The type of stove can be seen on the supplied CE label.



ATTENTION!

The appliance shall not be installed with ventilating systems which have pressure below -15 Pa.



ATTENTION!

Before the stove may be put to use, the set-up must be reported to your local chimney sweeper.



ATTENTION!

RAIS/ATTIKA recommends having the insert installed by an authorised technician. Please ask your dealer for further information.

MALFUNCTIONS

If you are experiencing disturbances, some of the most common causes are listed below.

SMOKE SPILLAGE AROUND THE DOOR

- This may be due to insufficient draft in the chimney <12Pa
- Check whether the flue or chimney is blocked
- Check whether the hood is switched on and, if so, switch it off and open a window / door near the stove for a short period.

SOOT ON GLASS

- Excessively wet firewood
- The damper regulation is too low
- Ensure proper heating of the stove when lighting, prior to closing the door

STOVE IS BURNING TOO STRONG

- Leak around the door seal
- Chimney draft too large >18 Pa, draft regulator should be installed.
- The damper is not regulated down enough

STOVE IS BURNING TOO WEAK

- Insufficient wood
- Insufficient air supply for room ventilation
- Unclean smoke flue
- Leaky chimney
- Leakage between chimney and flue

INSUFFICIENT DRAUGHT IN THE CHIMNEY

- Insufficient temperature difference, e.g., due to poorly insulated chimney
- High outside temperature, e.g., in the summer
- Absence of wind
- The chimney is too low and sheltered
- Leaks or other false air in the chimney
- Chimney and flue clogged
- The house lacks ventilation (lack of fresh air supply)
- Negative smoke extraction (poor draft conditions)

With a cold chimney or severe weather conditions, the poor draught can be compensated by supplying the stove with more air than usual.

If the interruptions persists, we recommend that you contact your RAIS dealer or chimneysweep.

SPARE PARTS

You can view the spare parts we offer by scanning the QR code if you need new ones for your product. The warranty disappears if replacement parts are used that are not recommended by RAIS. Your RAIS dealer is able to provide spare parts for all interchangeable parts.



SPECIFICATIONS

DTI Ref.: 300-ELAB-2211-EN

Viva L 100, Viva L 120, Viva L 140, Viva L 160, Viva L BC

| RAIS® | | Nominal | Standard: EN16510-2-1:2022 |
|--|--------------------|------------------------------|---|
| | | Wood logs | Fuel |
| P | kW | 5,6 | Nominal heat output |
| P _{SH} | kW | 5,6 | Space heat output |
| η | % | ≥ 75 | Efficiency |
| η _s | % | ≥ 65 | Seasonal space heat efficiency |
| EEL | - | 106 | Class A Energy efficiency index |
| CO (13% O ₂) | mg/Nm ³ | ≤ 1500 | CO emission at 13 % oxygen content |
| NO _x (13% O ₂) | mg/Nm ³ | ≤ 200 | NO _x emission at 13 % oxygen content |
| OGC (13% O ₂) | mg/Nm ³ | ≤ 120 | Hydrocarbon emission at 13 % oxygen content |
| PM (13% O ₂) | mg/Nm ³ | ≤ 40 | Particulate matter emission at 13 % oxygen content |
| p | Pa | 12 | Minimum flue draught |
| T _s | °C | 342 | Flue gas outlet temperature at the flue pipe collar |
| Tclass | - | T400 G | Chimney designation according to the appropriate chimney standard |
| Φ _{fg} | g/s | 4.7 | Flue gas mass flow |
| V _h | m ³ /h | 0 | Standing air loss |
| CON or INT | - | INT | Intermittent operation (INT) |
| t | min | 50 | Fuelling time |
| M _a | kg | 1,4 | Recommended wood quantity when filling (Divided into 2-3 pieces of firewood) |
| d _{out} | mm | 150 | The diameter of the flue pipe collar |
| L, W, H | mm | Ø470 H1000/ 1218/ 1413/ 1618 | Overall dimensions of the appliance (diameter/height) |
| L _c , W _c , H _c | mm | 352/292/305* | Combustion chamber (length/width/height) |
| m | kg | 100 - 130 | Mass of the appliance |
| m _{chim} | kg | 20 | Maximum load of the chimney |
| Type | - | CA | Appliance intended to be supplied with combustion air via a combustion air duct |

*Max. load limit

RATING PLATE

All RAIS/attika stoves have a rating plate indicating the stove's distance to combustibles, efficiency etc. The name-plate can also be found by scanning the QR code.

WITHOUT SIDE GLASS

WITH SIDE GLASS

| Set-up distances | | Viva L without side glass | Viva L with side glass | |
|---|----|---|------------------------------|---|
| d _R | mm | 75 | 75 | Minimum distance from the back of the stove to combustible material |
| d _S | mm | 400 | 500 | Minimum distances from the sides to combustible material |
| d _C | mm | 450 | 450 | Minimum distances from the top of the door to combustible material at the ceiling |
| d _P | mm | 850 | 800 | Minimum distances from the front to combustible material (Distance to furniture) |
| d _F | mm | 0** | | Minimum distances from the front to combustible material in bottom front radiation area |
| d _L | mm | 0** | | Minimum distances from the front to combustible material in side front radiation area |
| d _B | mm | 270 | | Minimum distance from the bottom edge of the door to the floor. |
| d _{non} | mm | 50 | | Minimum distances to non-combustible walls |
|  | | Read and follow the user operating instructions | | |

**0 mm: Since 65 K is not exceeded by radiation on the floor in front and/or on the side wall. Cf. EN16510 Note 3.

The stove was tested and approved by:
 DTI - Danish Technological Institute
 Teknologiparken Kongsvang Allé 29
 8000 Aarhus C, Denmark
 www.dti.dk
 Tel.: +45 7220 2000,
 Fax: +45 7220 1019

Read the section about installation distances in the installation guide.



SHARED FLUE

IMPORTANT! it is **NOT** allowed to connect multiple stoves to the same chimney in the **UK**.

In other countries it is permitted to connect several stoves to the same chimney, provided that the two stoves have the same owner, as in an example where a house has two floors with one stove in the living room and one on the first floor. It is a requirement that the inlets must be positioned so that there is a clearance difference between them of at least 250 mm.

IN CASE OF MARKET CONTROL

The specifications are based on nominal test results. During the nominal test, an ignition and two pre-fires are used to generate a basic glow layer of approximately 280 g prior to the test firing. The test firing includes 1.4 kg of two pieces of firewood, the door is closed immediately after filling. From here, approximately 5 test cycles are carried out, each of which ends when the weight reaches about 20 g. The weight at the end of the cycle must not differ by more than 100 grammes from the previous cycle.

The user manual includes a more detailed description of how to conduct the nominal test.

DECLARATION OF PERFORMANCE



DECLARATION OF CONFORMITY



To clarify whether the stove installation wall is flammable or otherwise, contact your building architect or local building authorities. Please make sure that objects made of combustible materials (such as furniture) are not placed closer than the distances indicated in the following tables (fire risk).

MINIMUM DISTANCE FOR CEILINGS AND FLOORS

Distance to the ceiling from the top of the door minimum 450 mm. Distance to the floor from the door bottom is minimum 270 mm.

IMPORTANT

Please bear in mind that the installation distances on the following pages only apply to the wood-burning stove. The final choice of Chimney solution may have a larger safety distance to the flammable material. The Chimney solution must always be installed in accordance with current building regulations and in a manner that ensures CE-marking compliance. Always make sure to follow all local precautions, including those referring to national and European standards.



FURNISHING DISTANCE FOR STOVES WITH A ROTATING BASE

If you have an stove with a rotating base, it is important that you maintain the furniture distance all the way around the stove.

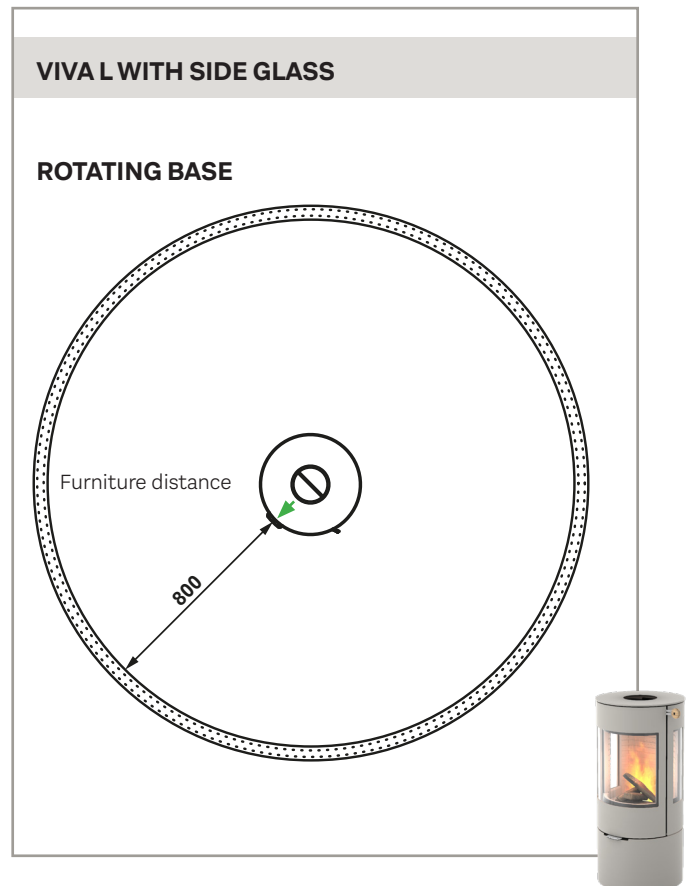
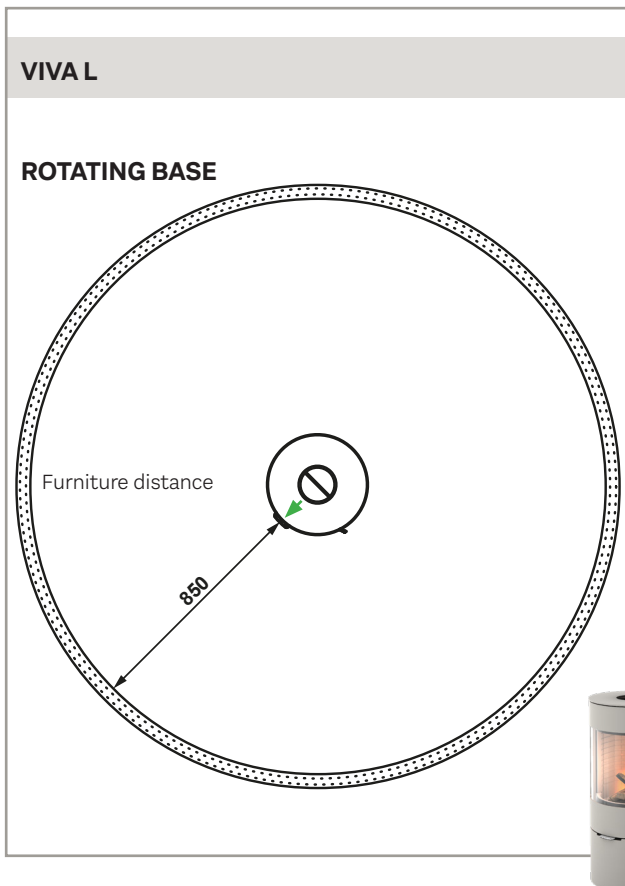

VIVAL

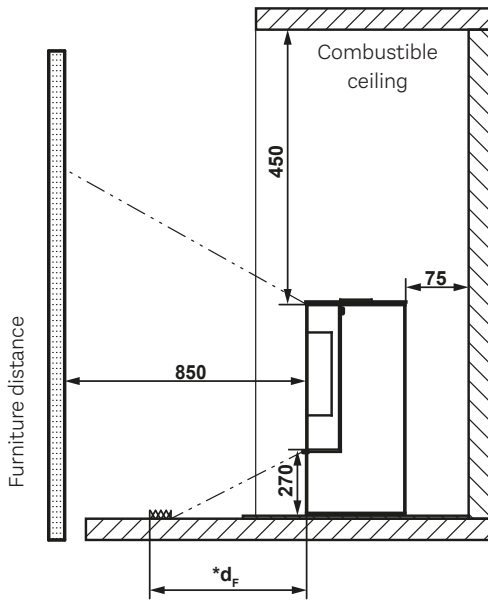

*0 mm: As 65 K is not exceeded by radiation on the floor in front and/or on the side wall.

VIVA L WITH SIDE GLASS

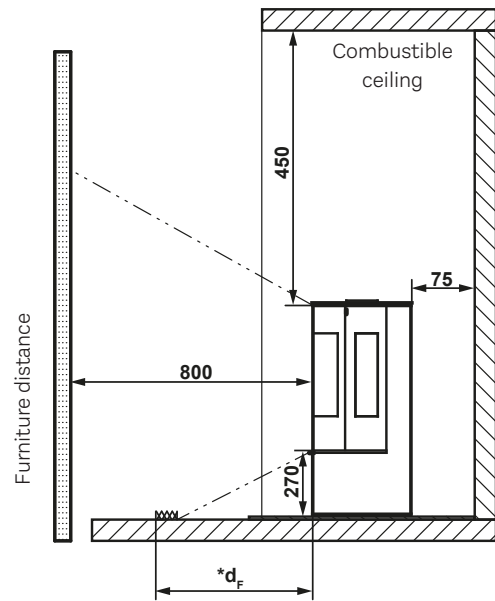

*0 mm: As 65 K is not exceeded by radiation on the floor in front and/or on the side wall.

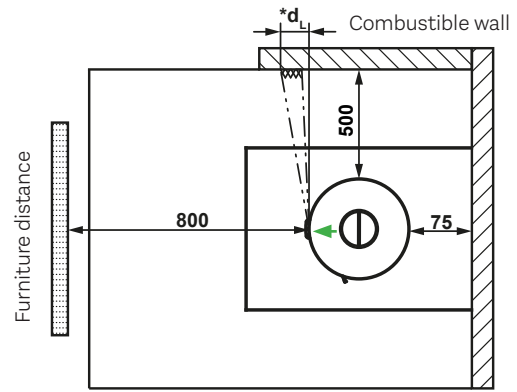
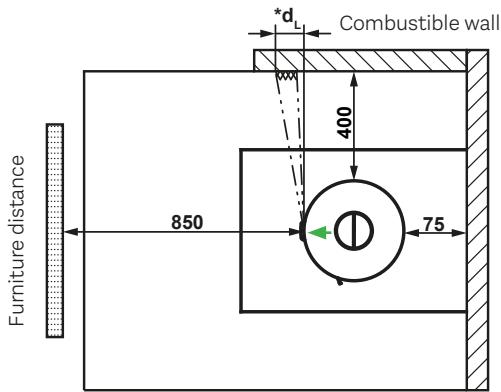

CORNER SET-UP

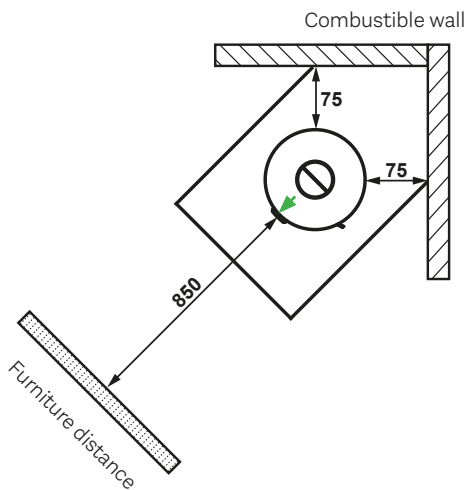

CORNER SET-UP

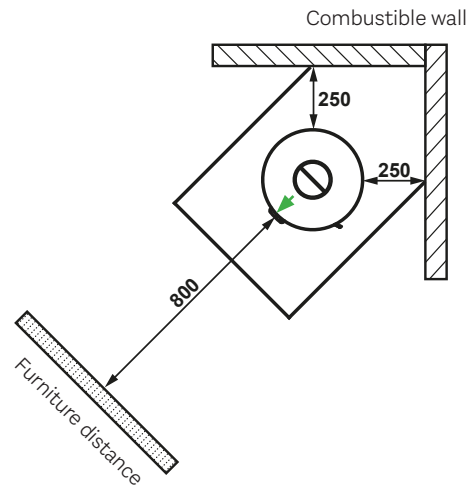

INSTALLATION DISTANCE IN CASE OF NON-COMBUSTIBLE WALL

We recommend a minimum distance to non-combustible material of **50 mm** for cleaning purposes.

ENG

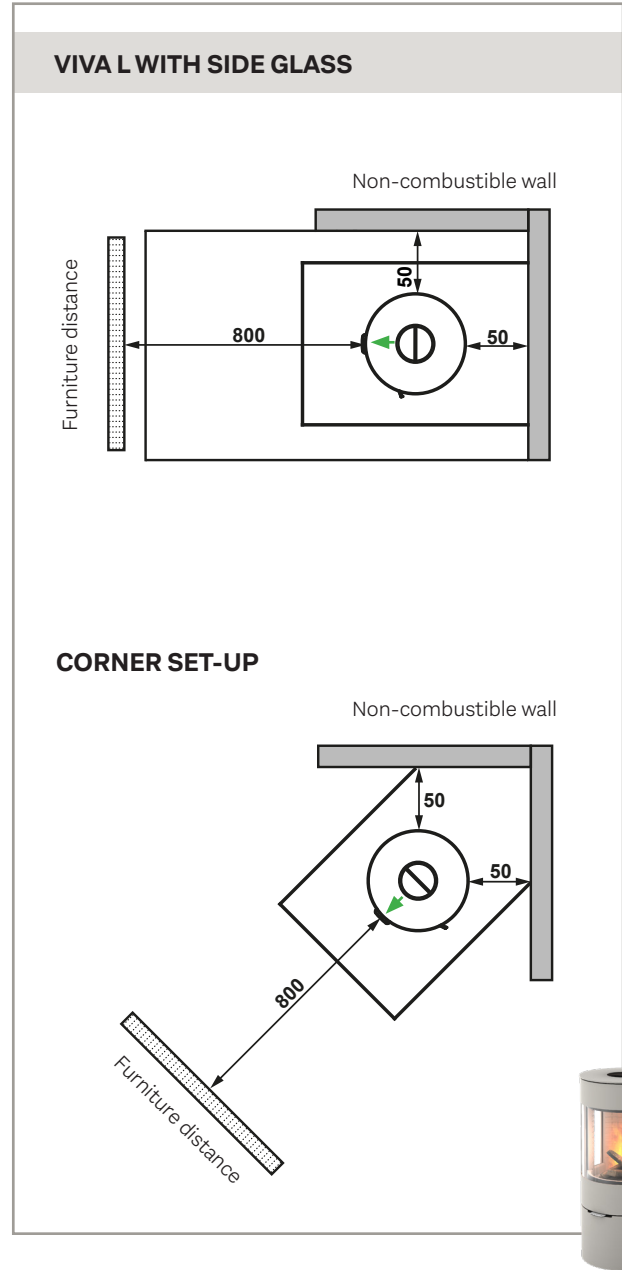
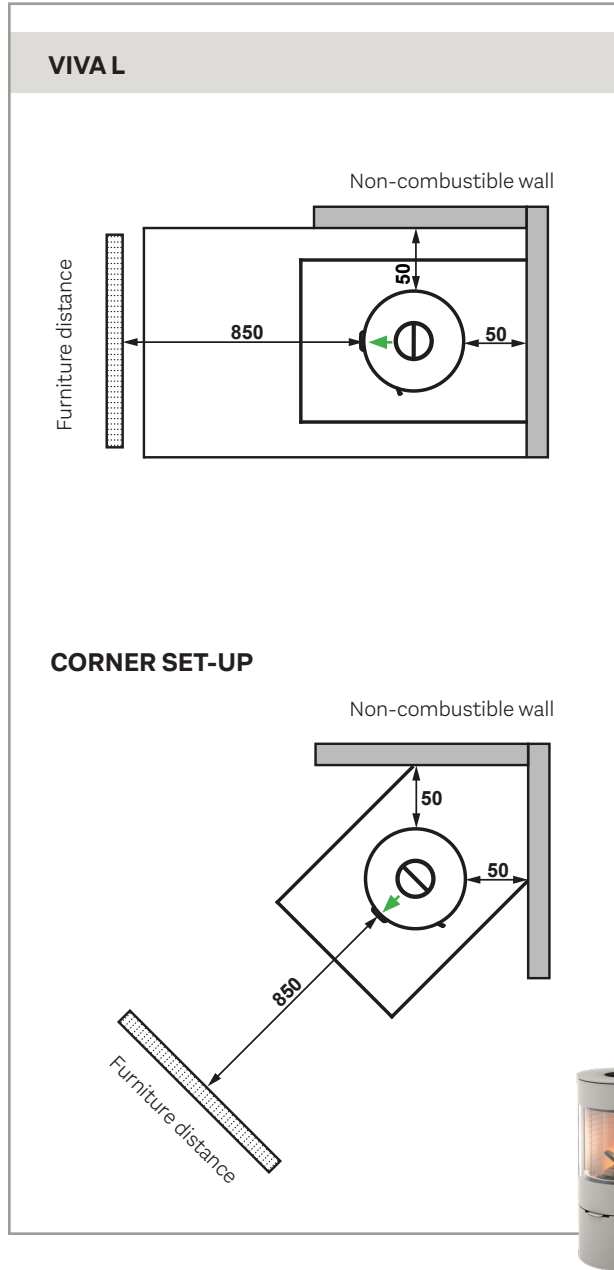

DIMENSIONAL SKETCH: VIVA L 100

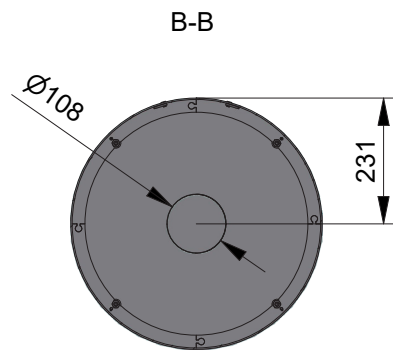
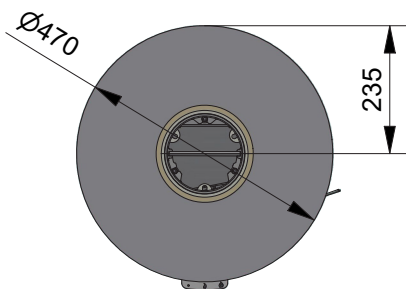
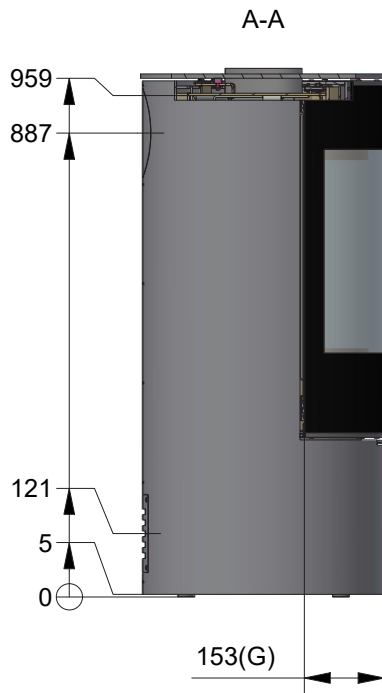
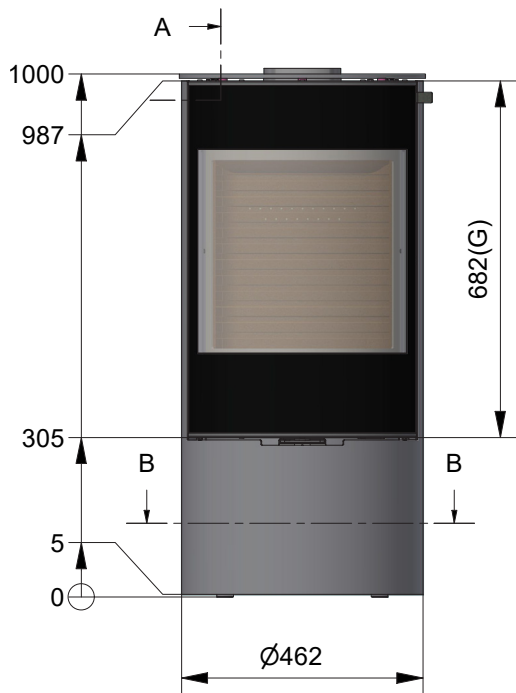

DIMENSIONAL SKETCH: VIVA L 100 WITH SIDE GLASS

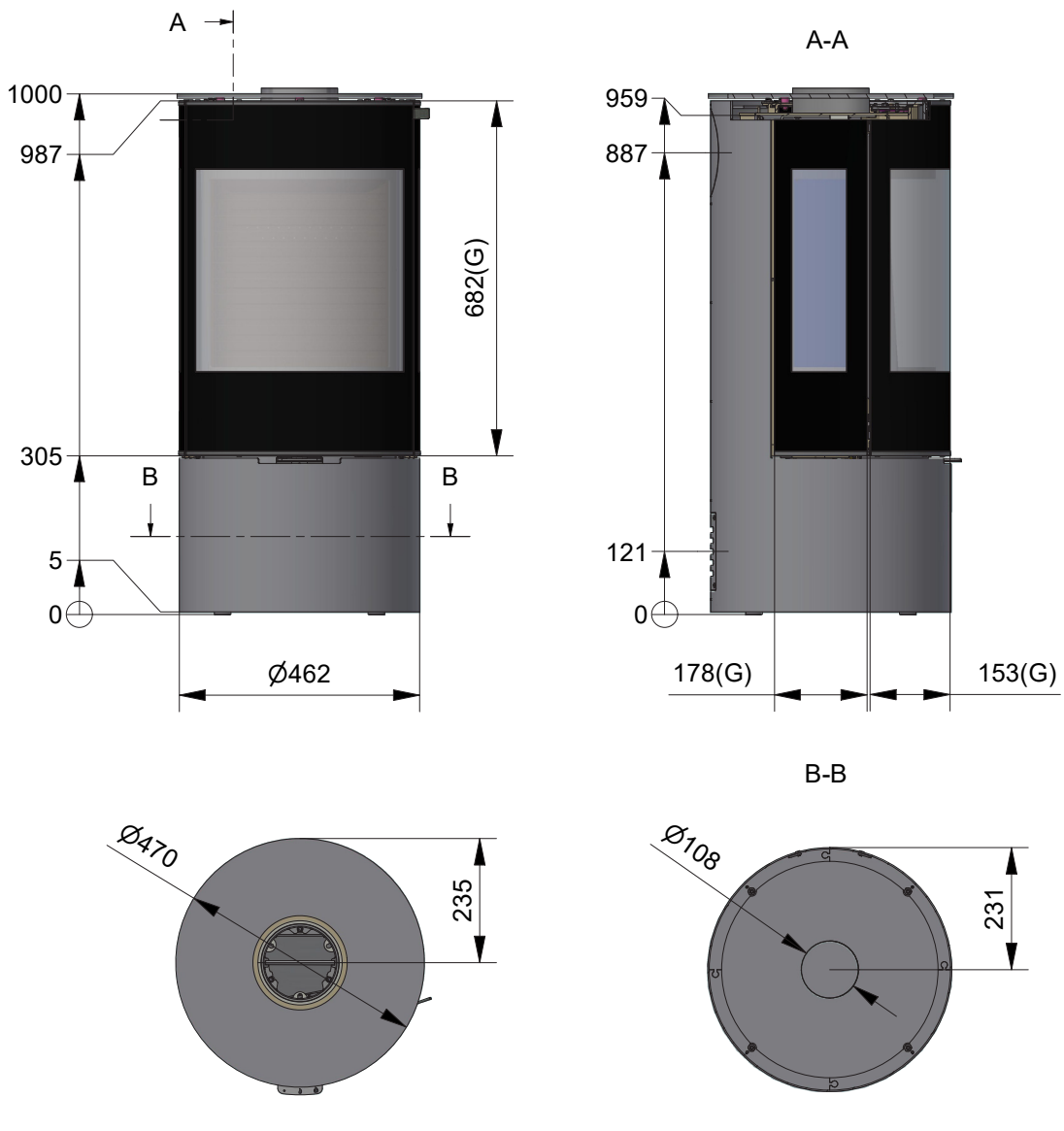

DIMENSIONAL SKETCH: VIVA L 120

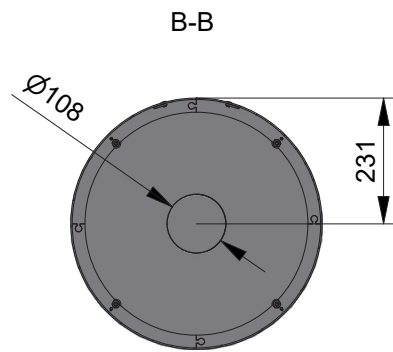
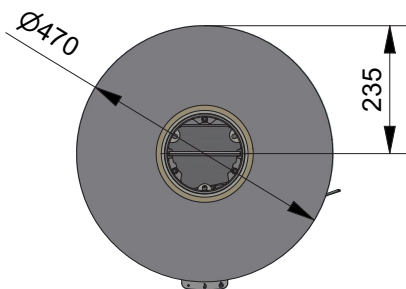
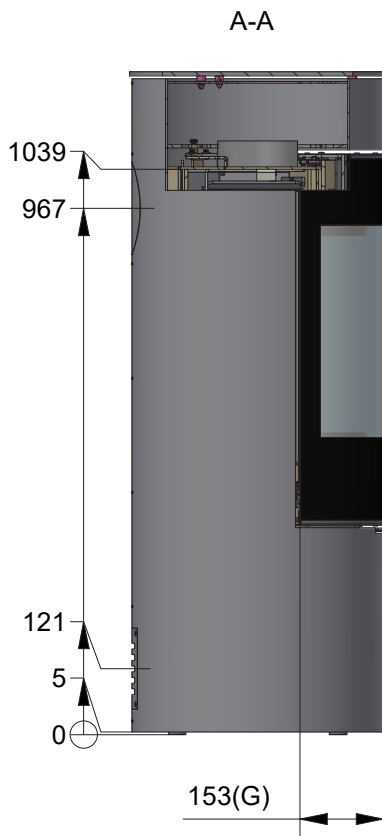
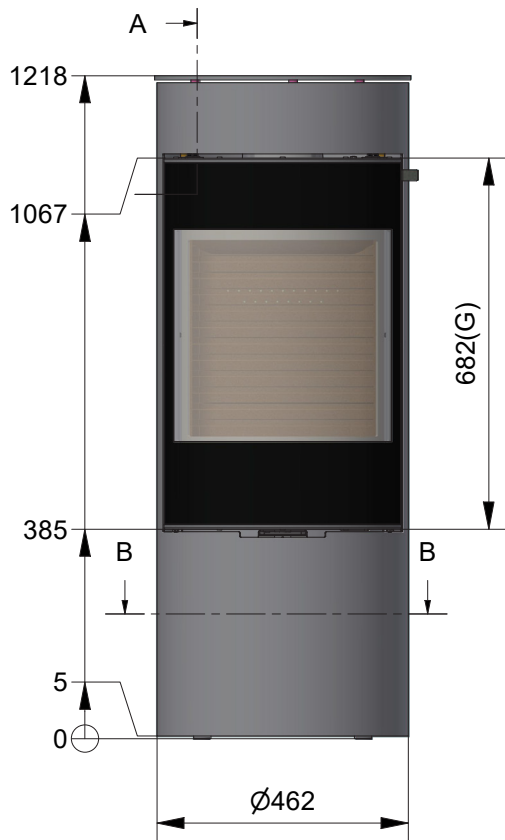

DIMENSIONAL SKETCH: VIVA L 120 WITH SIDE GLASS

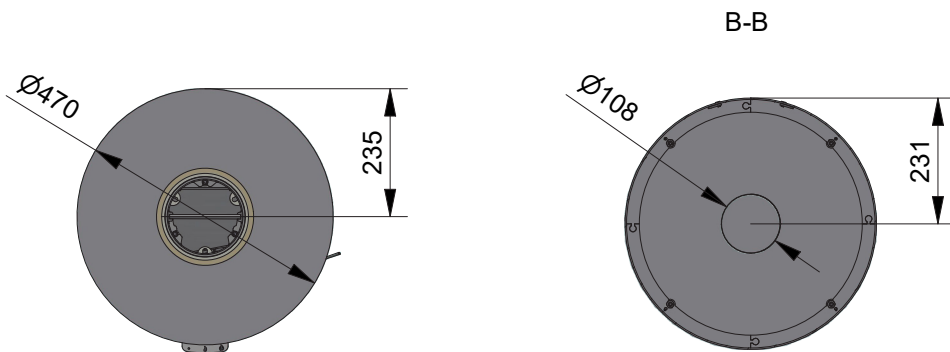
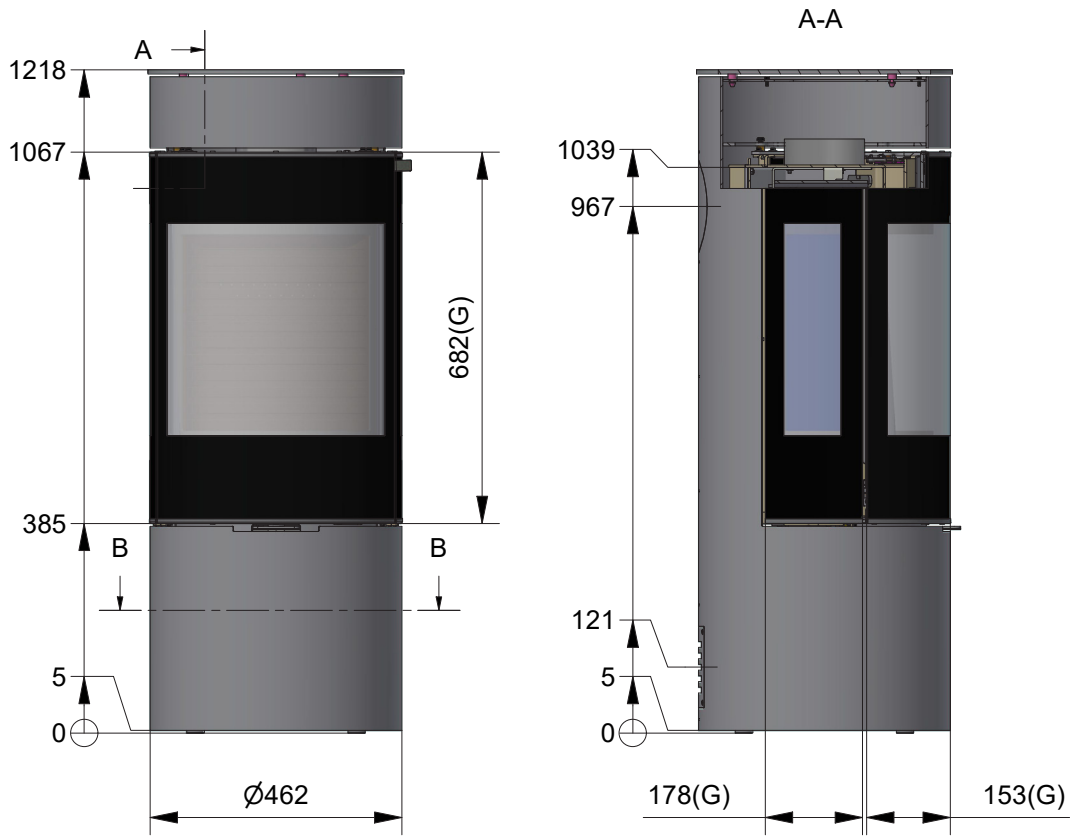

DIMENSIONAL SKETCH: VIVA L 140

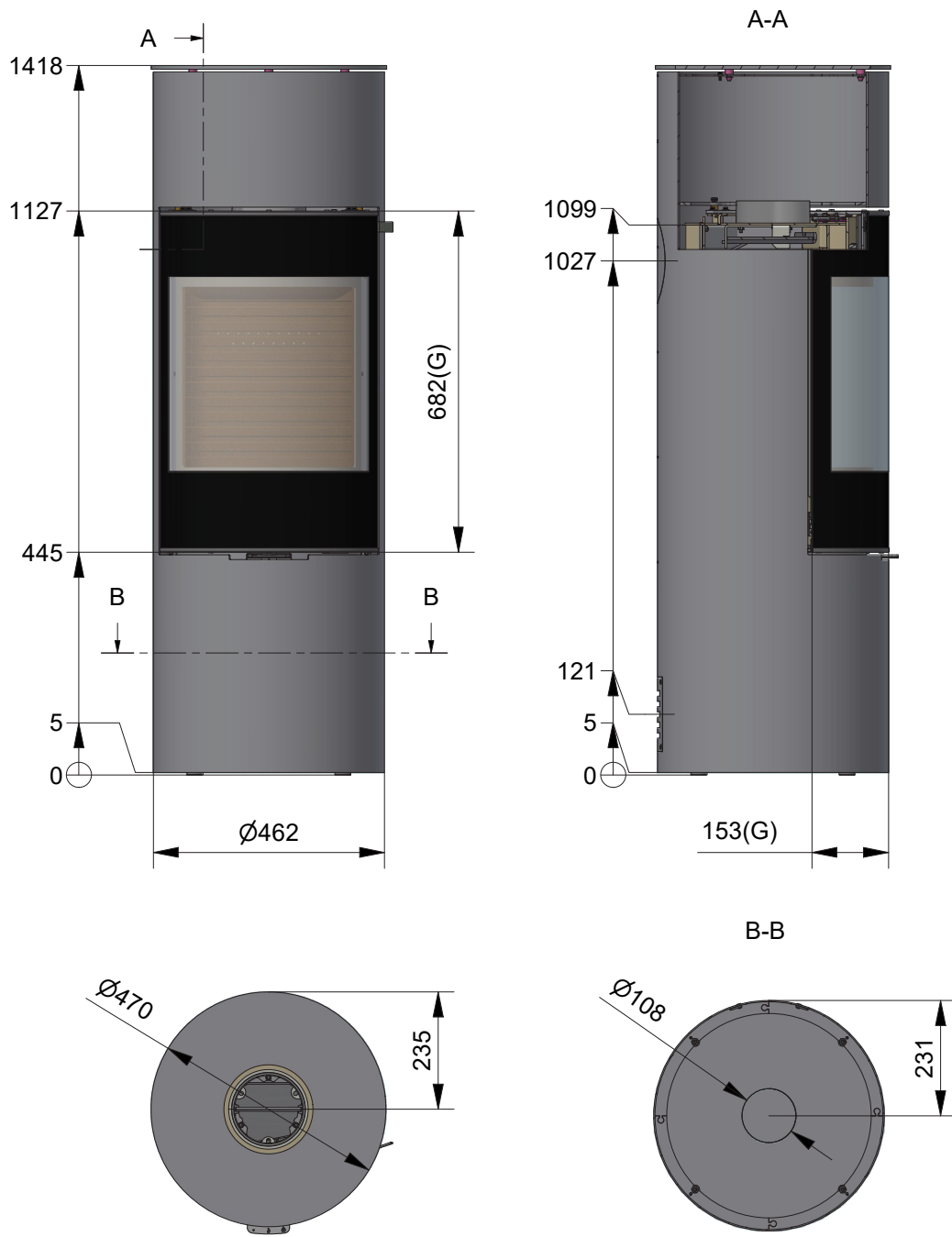

ENG

DIMENSIONAL SKETCH: VIVA L 140 WITH SIDE GLASS

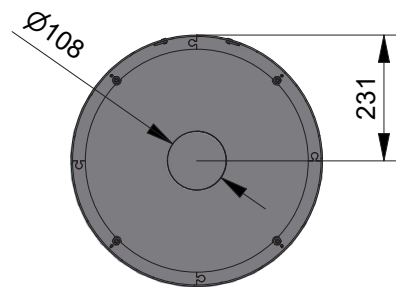
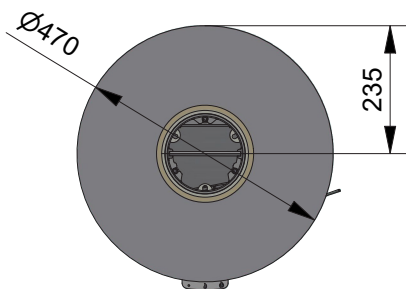
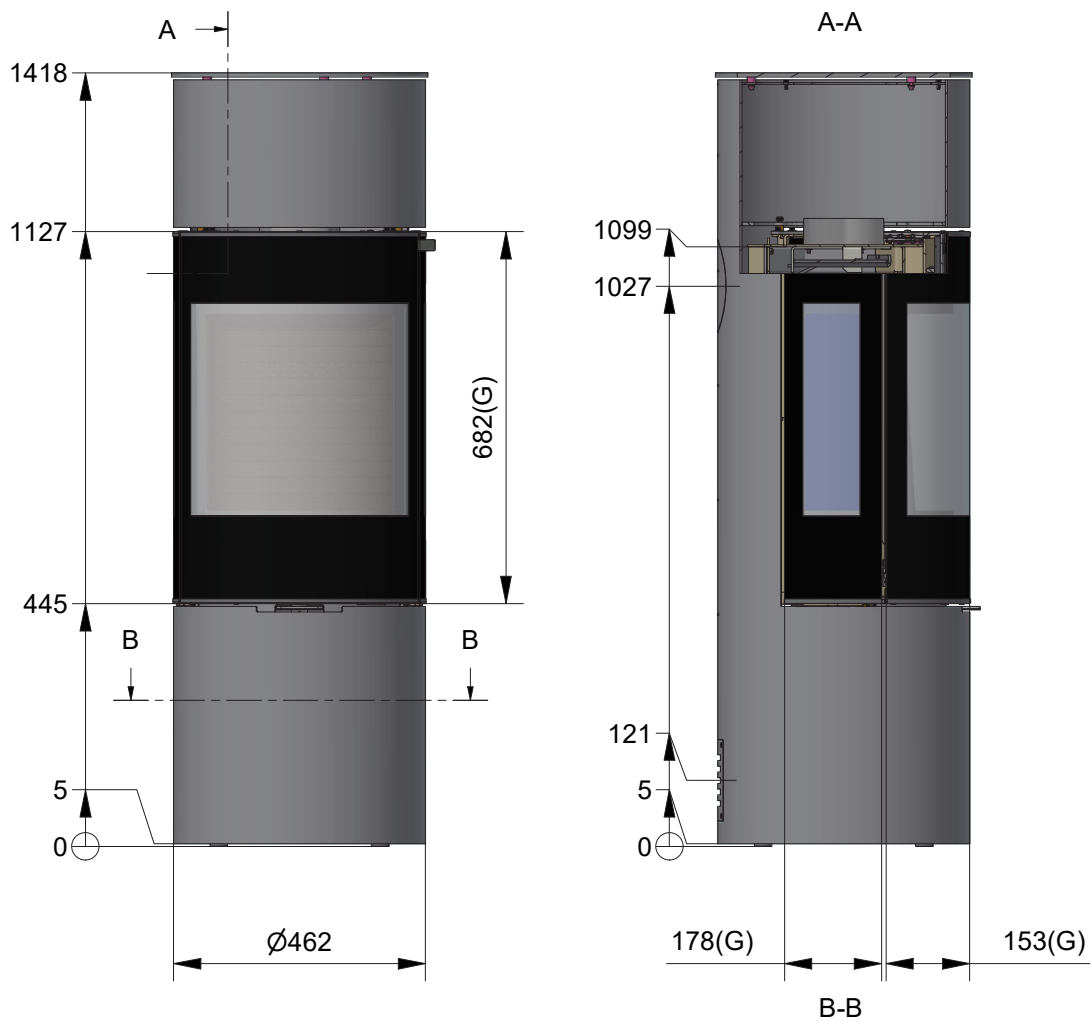

DIMENSIONAL SKETCH: VIVA L 160

ENG

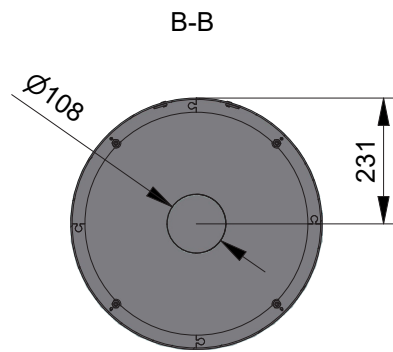
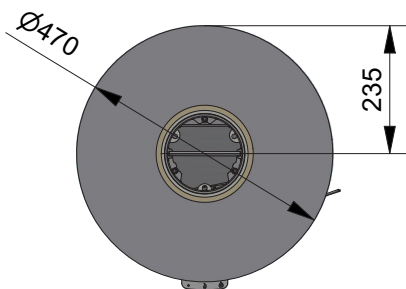
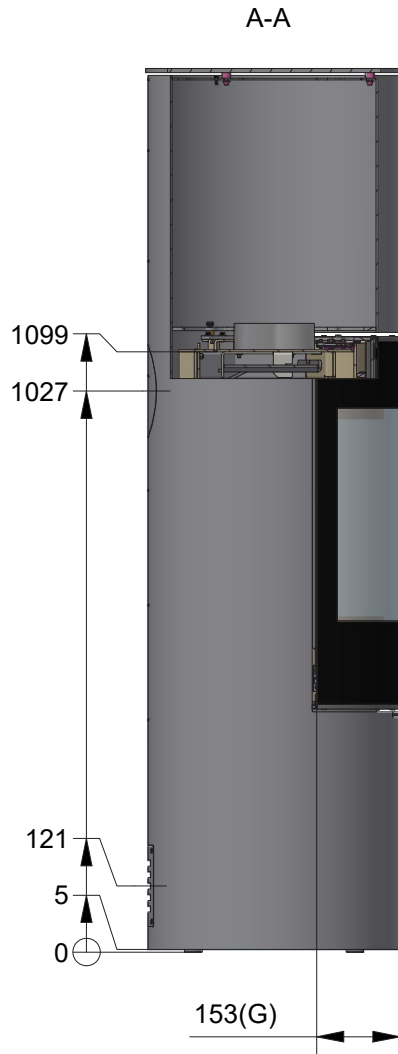
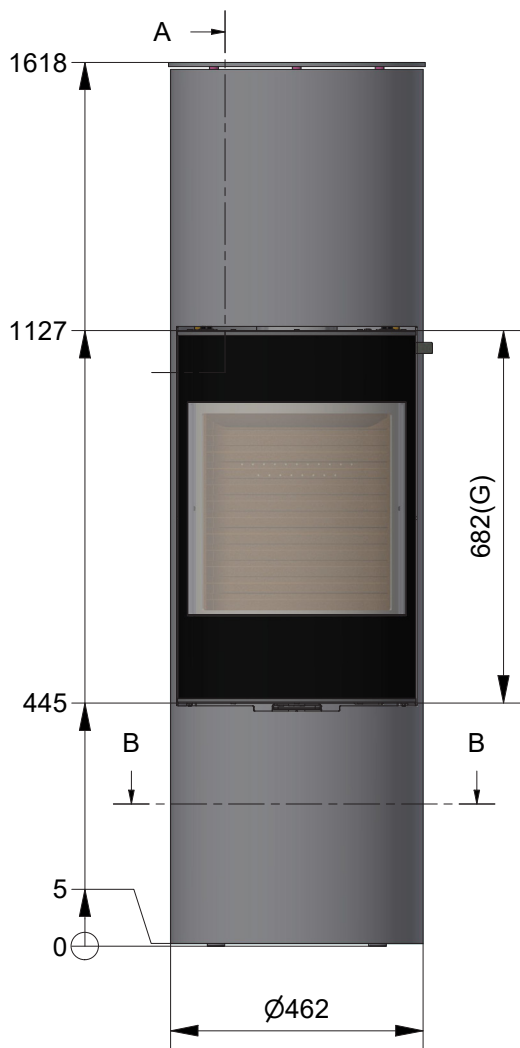

DIMENSIONAL SKETCH: VIVA L 160 WITH SIDE GLASS

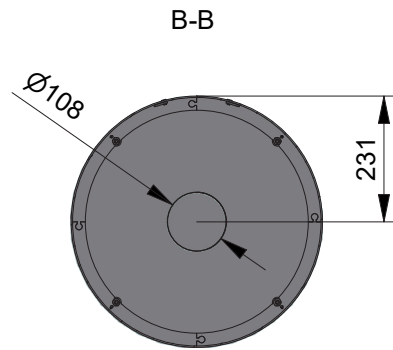
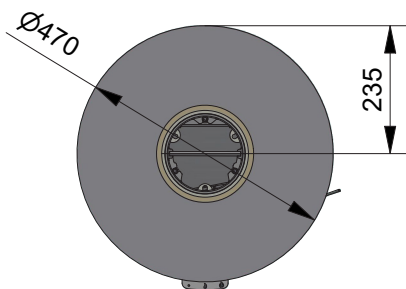
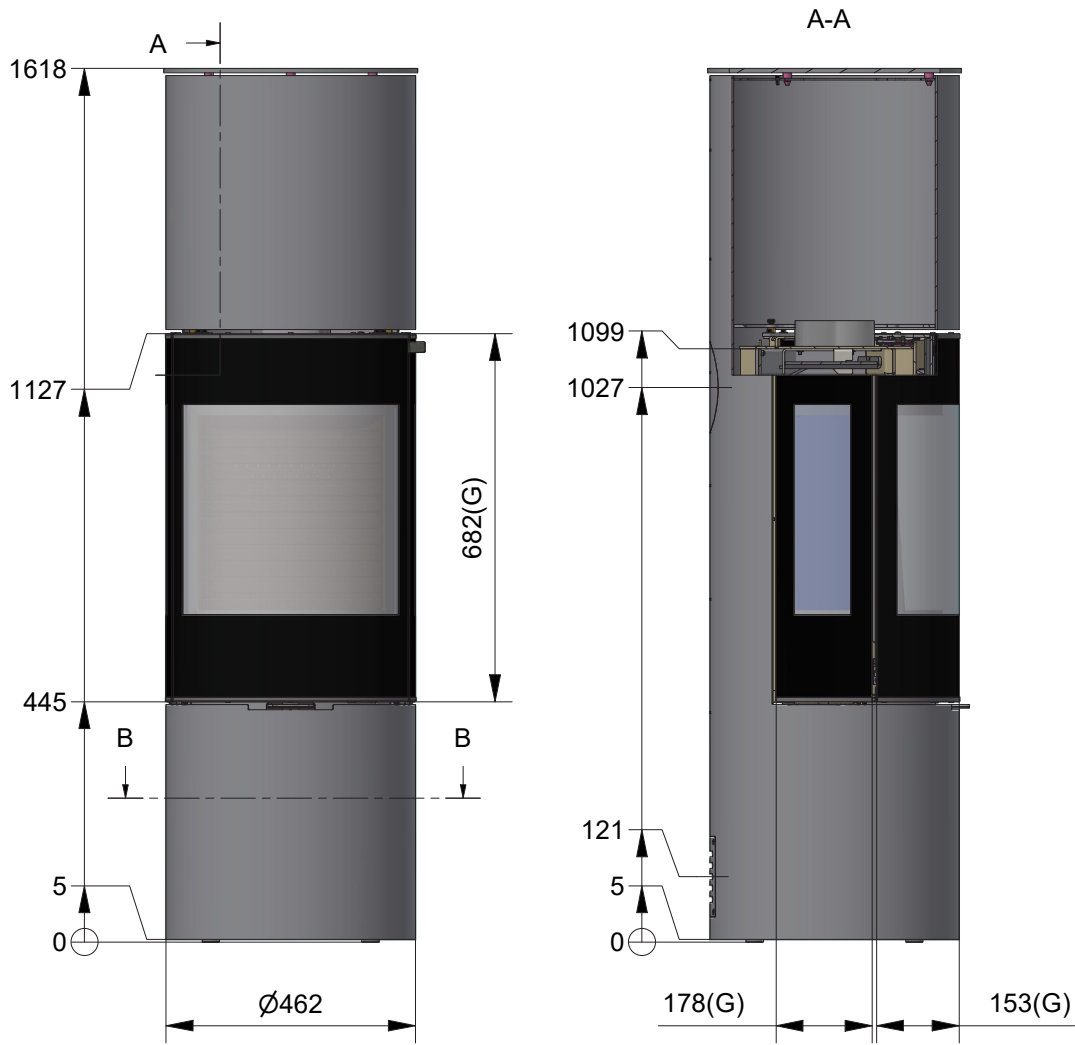

DIMENSIONAL SKETCH: VIVA L BC

ENG

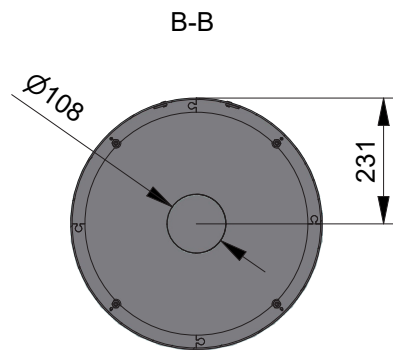
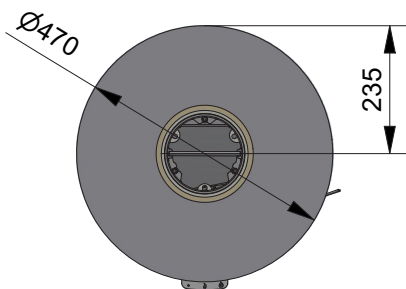
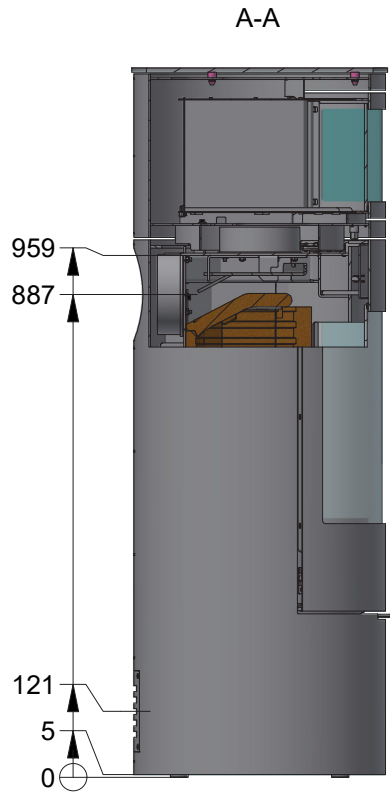
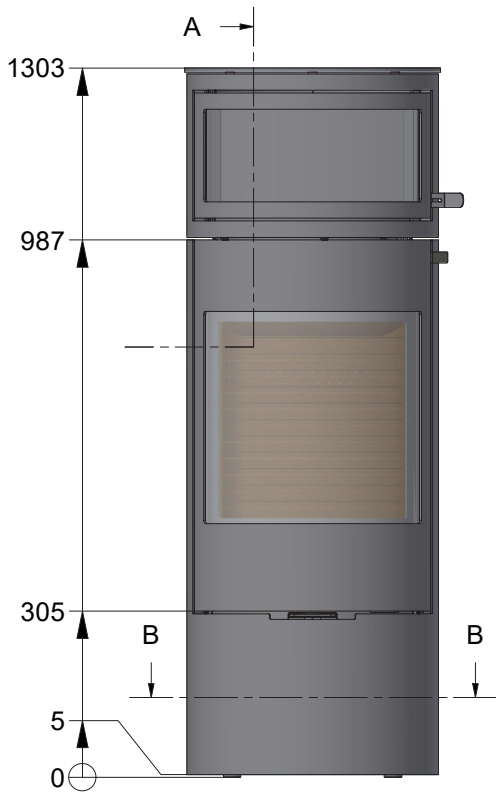



RECYCLING OF PACKAGING

The stove is delivered in recyclable packaging. This packaging must be disposed of in accordance with national regulations relating to the disposal of waste.



Plastic straps

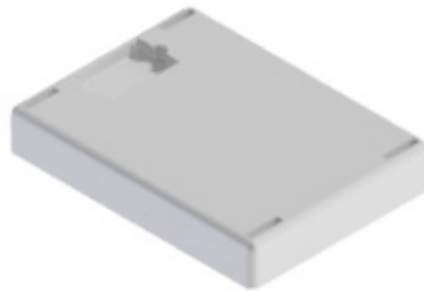

Styrofoam



Cardboard

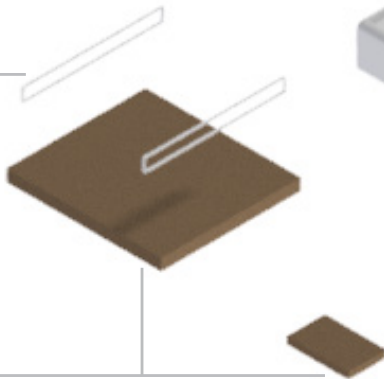

Plastic

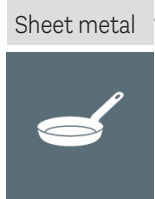

Sheet metal

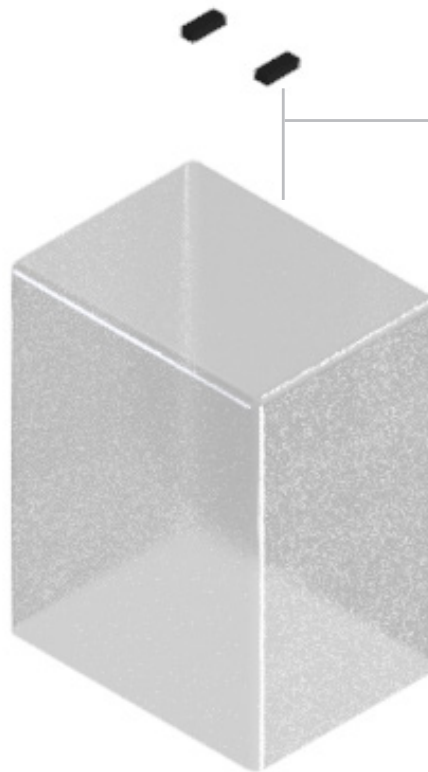

Pallet wood



DISPOSAL AFTER END OF LIFE

When your stove can no longer be used in the distant future, it is important that it is disposed of correctly. At the end of the user manual you will find an overview of how to dispose of the stove itself at the end of its service life.



PACKAGING AT DELIVERY

Upon delivery, the stove is secured to a transport pallet using four transport safety fittings. The safety fittings are attached with screws which must be unscrewed. The safety fittings can then be removed.

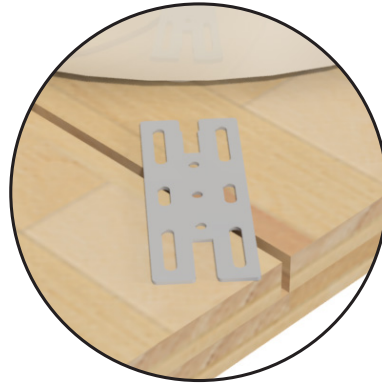
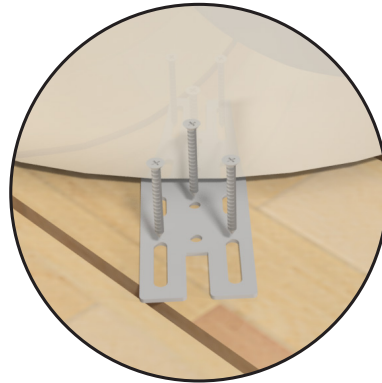

HEIGHT ADJUSTMENT

There are four adjustment screws underneath the appliance. Make sure the stove is level by using the adjustment screws.



FITTING THE SMOKE OUTLET IN THE TOP OUTLET

The stove is prepared for top outlet on delivery. Mount the flue outlet with the nuts and bolts supplied.



CHANGING THE CHIMNEY CONNECTION

The stove is delivered ready for top outlet, but can be changed to rear outlet as follows.

1. First, remove the firebox liner (see next page) and the top plate.
2. At the back of the stove there is a knock-out mould that needs to be knocked out. It is secured with four small pins.
3. Remove the knock-out mould with a hammer or similar.
4. Remove the flame cover (1) and gasket (2) from the back and install on top.
5. Mount the flue outlet (3) on the rear outlet.



REMOVING THE COMBUSTION CHAMBER LINING

To reach the flue, carefully remove the vermiculite smoke deflector plates. Remove the smoke deflector plate by lifting up and turning sideways. Remove the smoke baffle by lifting it up and forwards so that it comes free of the fixings. Then, carefully insert in reverse order. The same procedure is used when changing the chimney connection for access to the flap cover.

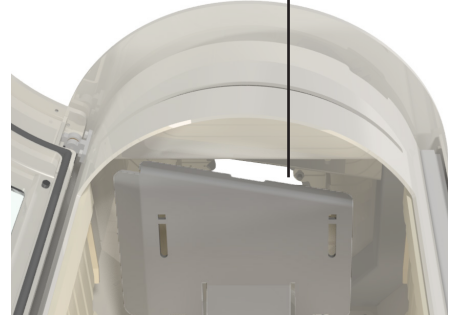
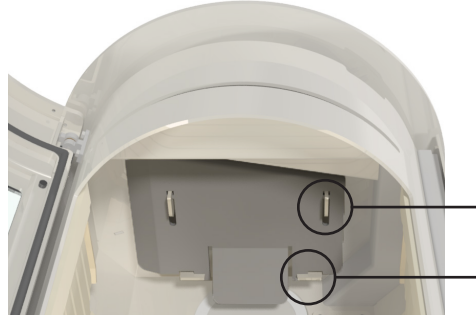
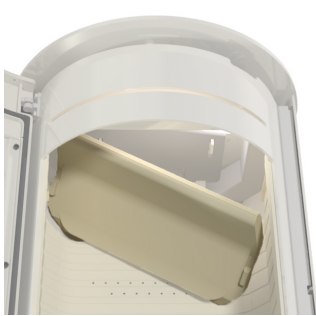
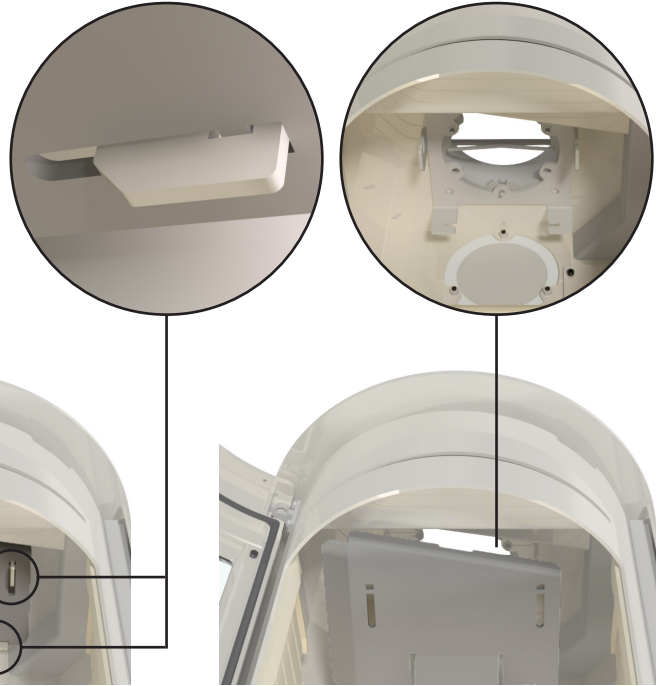

Remove the smoke deflector plate by lifting up and turning sideways.

The smoke baffle by lifting it up and forwards to release it from the fixings.

ATTENTION!

Take care when putting back the smoke deflector plates.



HEAT ACCUMULATION STONES

It is possible to install heat accumulation stones in the stove. The height of your stove determines the number of stones the stove can hold. Place the layers 90 degrees apart from each other.

- Viva L 100 - x
- Viva L 120 - 24 kg. equivalent to 4 stones
- Viva L 140 - 48 kg. equivalent to 8 stones
- Viva L 160 - 96 kg. equivalent to 16 stones



MOUNTING THE TOP PLATE

The top plate is equipped with three fixed fixation points, as shown in the image. Place the top plate in the indicated grooves on the stove and rotate it so that it cannot be lifted off directly. There are several different top plates available, these are mounted in the same way as shown.

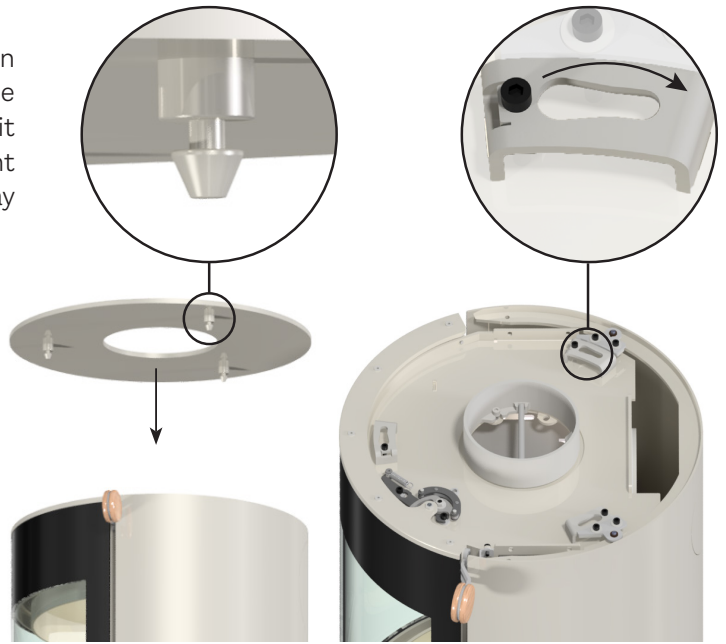

MOUNTING/CHANGING THE HANDLES

On delivery, the stove is fitted with a temporary handle. This is removed by removing the screws. The new handle can then be mounted on the stove with the screws.

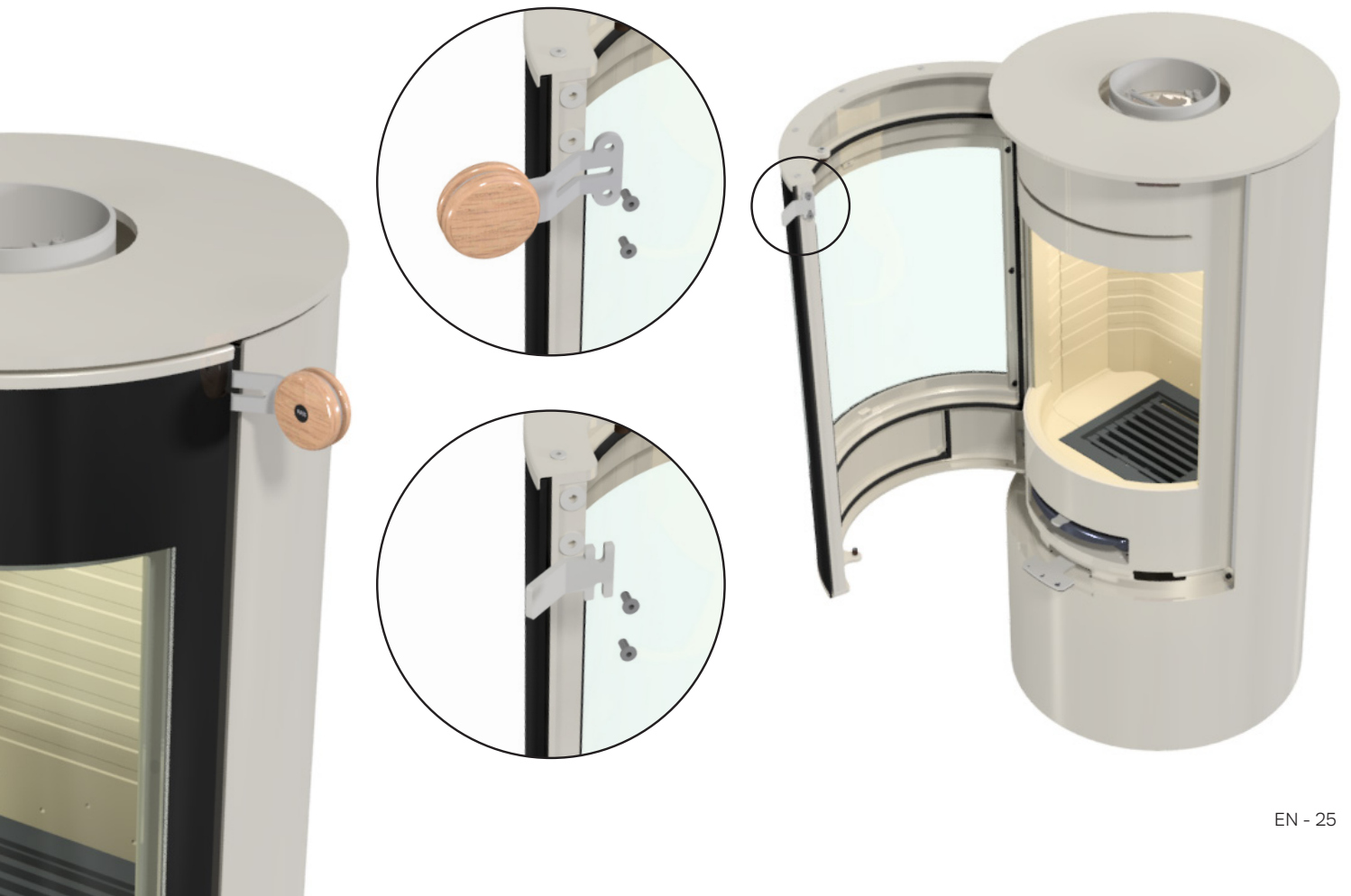

SWIVEL BASE

Available with and without a swivel base. If supplied with a swivel base, the foot is mounted under the stove and secured with two wing nuts.

The foot can be set to:

- turn 90° (45° to each side) - (set when delivered)
- turn 360°

Start by removing the air inlet cover on the back of the stove.

To ease installation the stove has been angled 45° to the left at the factory. This ensures easy access to the wing nuts, which must be removed after installation.

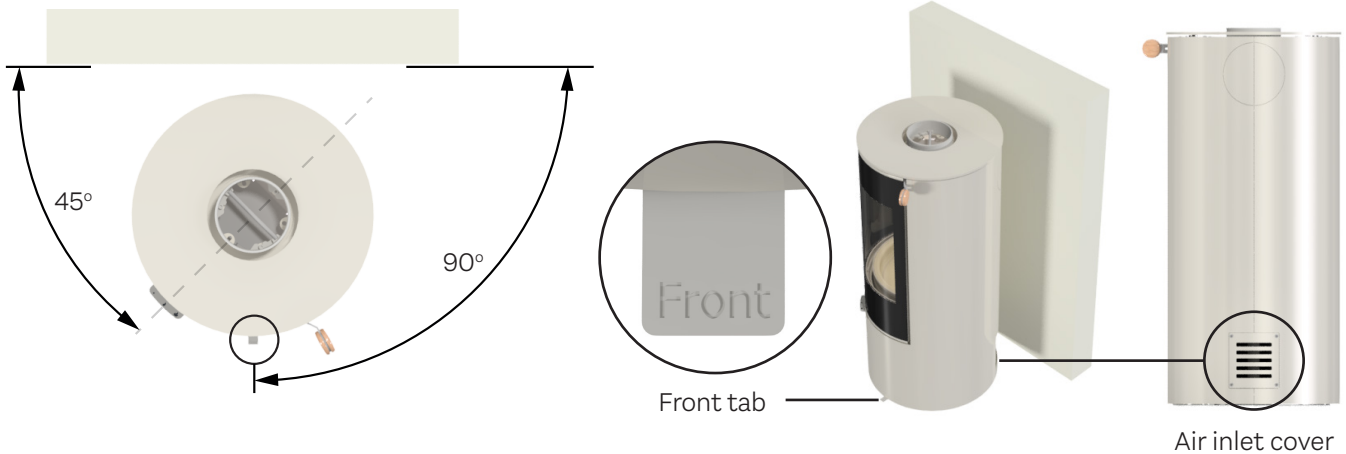

The plastic tab marked “FRONT” marks the stove’s actual centre point and is on the front of the swivel foot. The tab must therefore be at 90° in relation to the wall when installing. Remove when installation is complete by pulling gently.

Once the stove is in place, remove the wing nuts to release the swivel base.

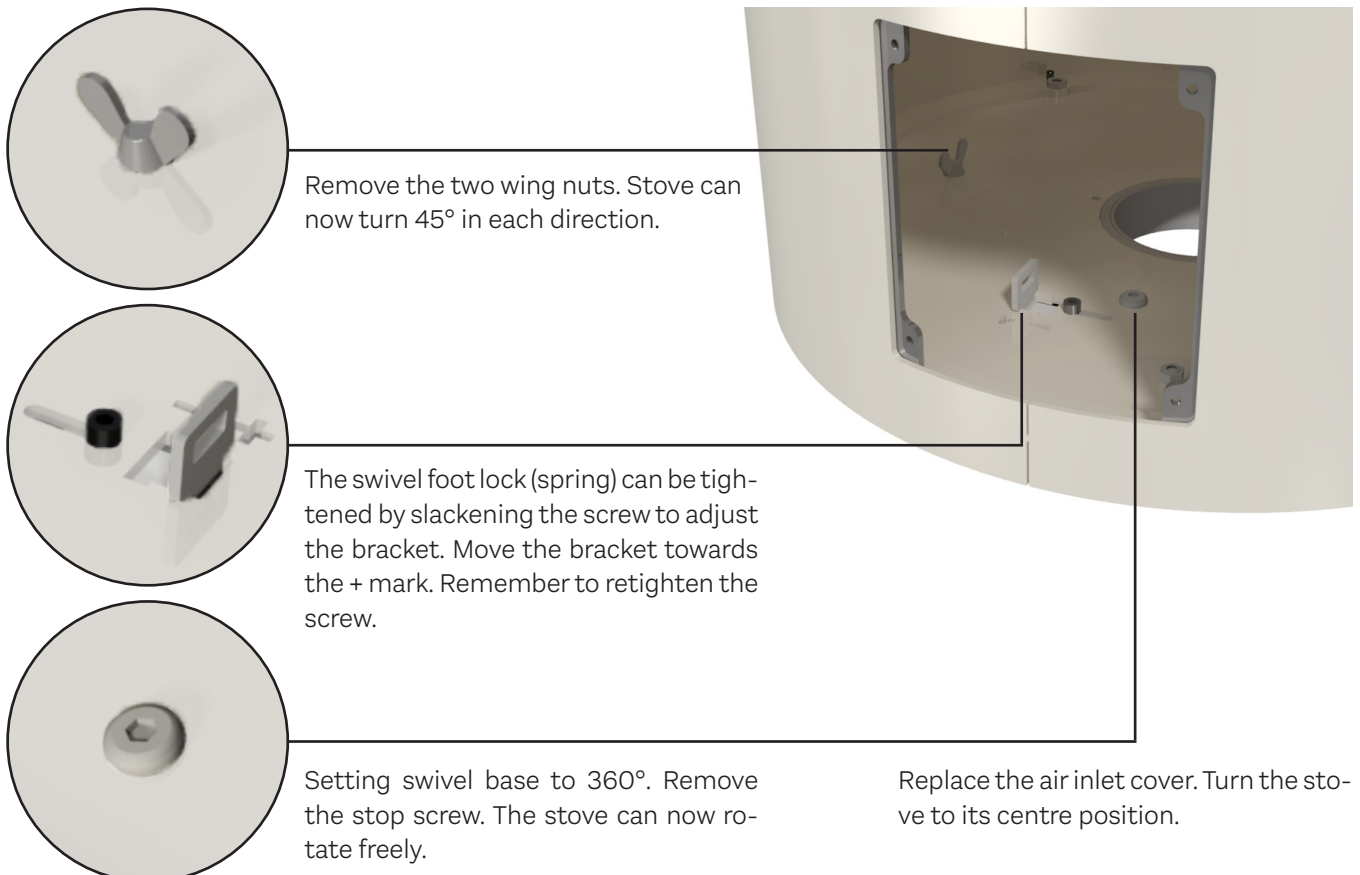

Remove the two wing nuts. Stove can now turn 45° in each direction.

The swivel foot lock (spring) can be tightened by slackening the screw to adjust the bracket. Move the bracket towards the + mark. Remember to retighten the screw.

Setting swivel base to 360°. Remove the stop screw. The stove can now rotate freely.

Replace the air inlet cover. Turn the stove to its centre position.

CLEANING AND MAINTENANCE

It is important that the stove is cleaned and maintained both inside and out. When this is done, the stove must be cold. The stove should be inspected by a chimney sweep once a year. Always check the chimney and flue collar for blockages before a heating season. Inspect the exterior and interior of the stove for damage, especially gaskets and the thermal insulation plates (vermiculite).

The combustion chamber lining protects the stove from heat from the fire. Due to the large temperature variations, cracks may appear in the combustion chamber lining. These can last for several years and should be replaced if they start to crack. The plates are loosely placed inside the combustion chamber and can easily be replaced by you or your dealer. For detailed instructions on how to replace the plates or remove them to clean the flue, see the user manual.

Lubricating door hinges and door locks is a necessary maintenance task that should be done on a regular basis rather than just after damage has occurred. It is advised that you use only our lubricant spray; using other products may cause residue and odour to form. To obtain the lubricant, contact with your dealer.



BLOCKING THE AIR INTAKE

It must always be possible to access the air intake cover, which is located on the back of the stove. The stove needs permanent and sufficient air in order to burn optimally and safely. It is therefore important that the air intake cover is not blocked or closed, as the stove takes air from the room through it, among other things.

When the stove is installed in a construction where direct combustion air is required, external air must be connected to the stove from the outside. All RAIS/attika stoves have the option to supply external air.

This external air supply is what we call AirSystem. The air intake for the system can be hidden by installing it either in the floor or in the wall behind the stove. If you order a stove with AirSystem, it is installed before you receive it from us. All you have to do is connect it in your home.

The maximum length of the flex hose is 5 metres. It is important that it is not bent and folded around corners so that the tube collapses and the airflow cannot get through as intended.

If the air supply is 5-10 metres from the stove, use a Ø120 mm flex hose instead.

The air valve must be set to the open position during use to allow outside air to enter the stove. If the stove is unused for a period of time, you can close the air vent to prevent cold air from entering the installation room.



ATTENTION!

In countries where legislation does not allow closing the air supply, the damper plate in the air valve must be removed.

AIR CONNECTION ON THE BACK

If you purchase a stove with rear air connection, mount the air valve (3) and gasket (2) on the wall above the hole leading to the outside. Then install the cover (5).

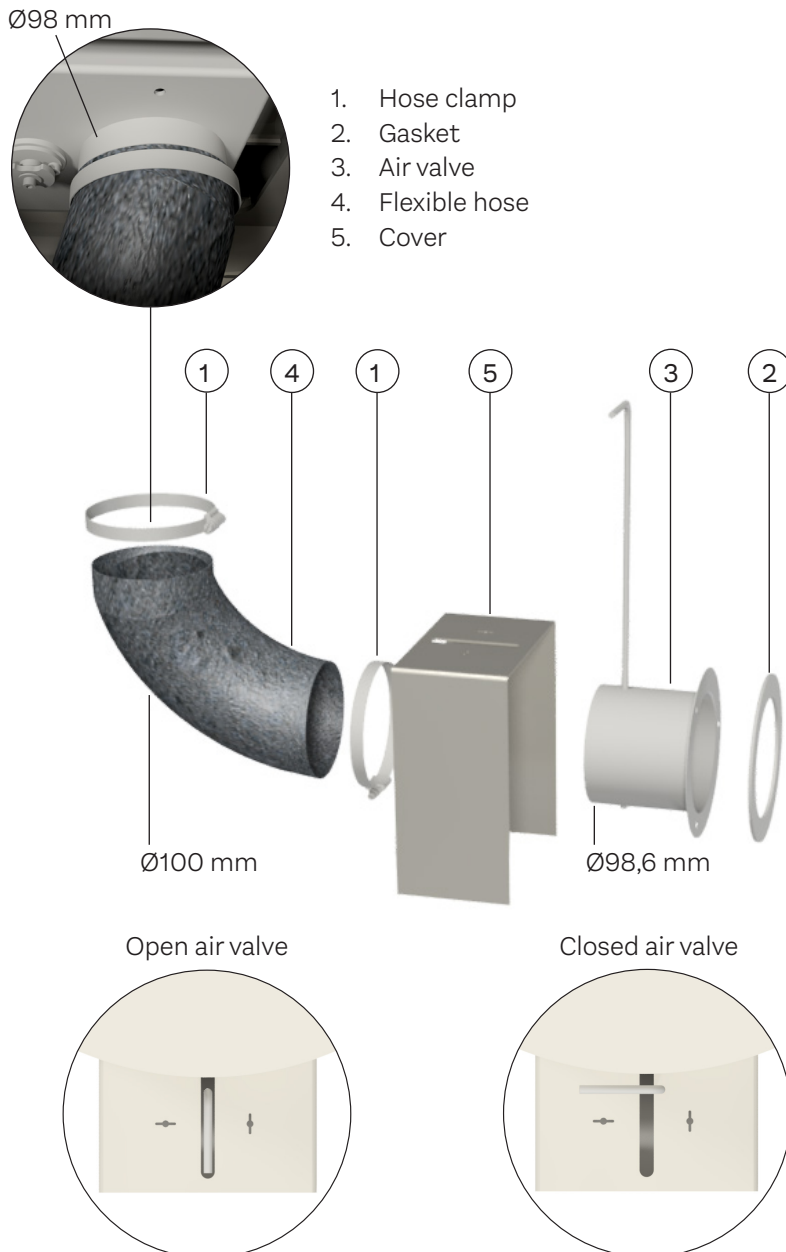

AIR CONNECTION AT THE BOTTOM

If you purchase an stove with bottom air connection, install the air valve (3) and gasket (2) above the hole in the base plate. The gasket (5) is mounted over the hole leading to the outside.

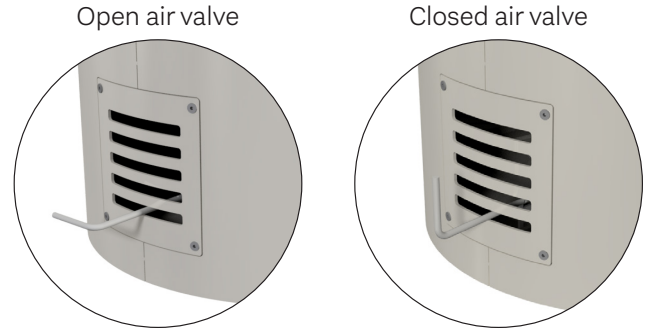

- 1. Hose clamp
- 2. Gasket
- 3. Air valve
- 4. Flexible hose
- 5. Gasket

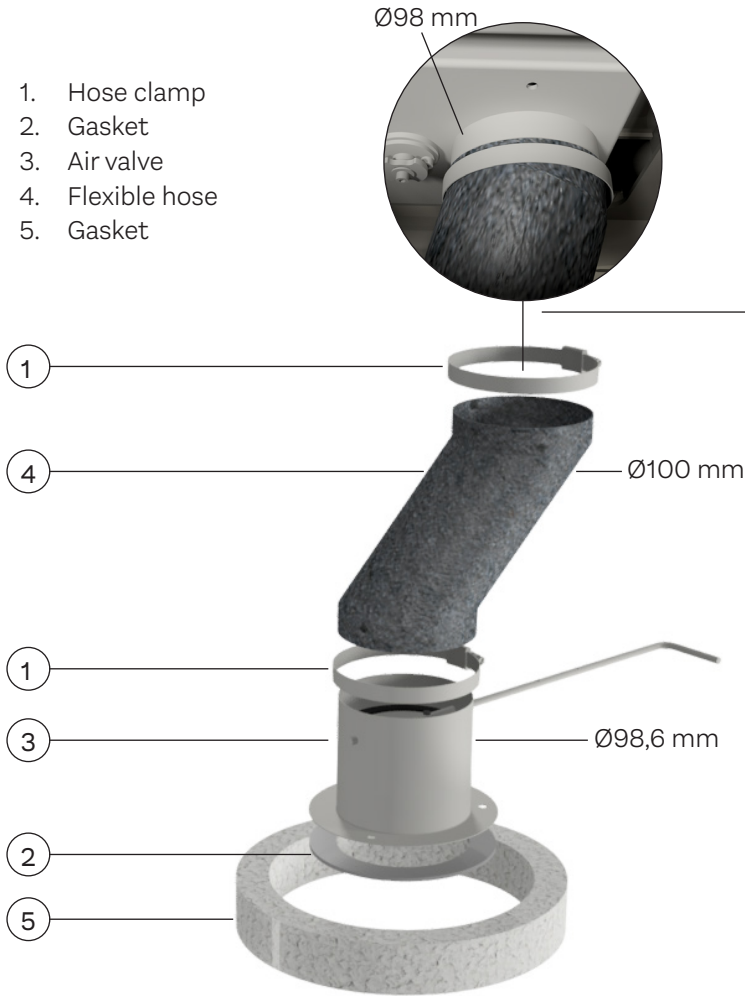

ENG

AIR CONNECTION AT THE BOTTOM WITH SWIVEL BASE

When purchasing a swivel base and bottom air connection, place the gasket (5) under the stove and centre it in the hole in the bottom of the stove before installation.

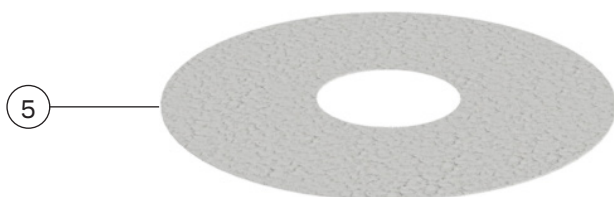

- 1. Hose clamp
- 2. Gasket
- 3. Air valve
- 4. Flexible hose
- 5. Gasket



PERMANENT AIR SUPPLY

The appliance needs a permanent air supply to the room of installation as the appliance is over 5kW, confer with Building regulation Approved Document J.

Permanently open air vents should be non-adjustable, sized to admit sufficient air for the purpose intended and positioned where they are unlikely to become blocked. see Approved Document J.

A CO Alarm must be fitted into the same room as the appliance upon installation. The alarm shall be compliant with British Standards BS 50291. Where battery powered alarms are selected, alarms with 'sealed for life' batteries rather than alarms with replaceable batteries are the better option.

THE CLEAN AIR ACT 1993 AND SMOKE CONTROL AREAS

Under the clean air act local authorities may declare the whole or part of the district of the authority to be a smoke control area. It is an offence to emit smoke from a chimney of a building, from a furnace or from any fixed boiler if located in a designated smoke control area. It is also an offence to acquire an "unauthorised fuel" for use within a smoke control area unless it is used in an "exempt" appliance ("exempted" from the controls which generally apply in the smoke control area).

In England appliances are exempted by publication on a list by the secretary of state in accordance with changes made to sections 20 and 21 of the clean air act 1993 by section 15 of the deregulation act 2015. In Scotland appliances are exempted by publication on a list by Scottish ministers under section 50 of the regulatory reform (Scotland) act 2014. Similarly, in Northern Ireland appliances are exempted by publication on a list by the department of agriculture, environment and rural affairs under section 16 of the environmental better regulation act (Northern Ireland) 2016. In Wales appliances are exempted by regulations made by Welsh ministers.

The secretary of state for environment, food and rural affairs has powers under the act to authorize smokeless fuels or exempt appliances for use in smoke control areas in England. In Scotland and Wales this power rests with the ministers in the devolved administrations for those countries. Separate legislation, the clean air (Northern Ireland) order 1981, applies in Northern Ireland. Therefore it is a requirement that fuels burnt or obtained for use in smoke control areas have been "authorised" in regulations and that appliances used to burn solid fuel in those areas (other than "authorised"

fuels) have been exempted by an order made and signed by the secretary of state or minister in the devolved administrations.

The Viva L (All variants) have been recommended as suitable for use in smoke control areas when burning wood logs.

FUEL OVERLOADING

The maximum amount of fuel specified in this manual should not be exceeded, overloading can cause excess smoke.

REFUELLING ON TO A LOW FIRE BED

If there is insufficient burning material in the firebed to light a new fuel charge, excessive smoke emission can occur. Refuelling must be carried out onto a sufficient quantity of glowing embers and ash that the new fuel charge will ignite in a reasonable period. If there are too few embers in the fire bed add suitable kindling to prevent excess smoke.

DAMPERS LEFT OPEN

Operation with the air control or appliance dampers open can cause excess smoke. The appliance must not be operated with air controls, appliance dampers or door left open except as directed in the instructions.

OPERATION WITH DOOR LEFT OPEN

Operation with the door open can cause excess smoke. The appliance must not be operated with the appliance door left open except as directed in the instructions.

**ATTENTION!**

This page is only relevant for appliances installed in United Kingdom.



Article number: 1716520ENG



5 708252 428089

RAIS[®]

RAIS A/S
Industrivej 20
DK-9900 Frederikshavn
Denmark
www.rais.com

attika[®]
FEUERKULTUR

ATTIKA FEUER AG
Brunnmatt 16
CH-6330 Cham
Switzerland
www.attika.ch